



ERMIS

WOOD STOVE



Manual and
User Guide



CONTENTS

page

| | |
|--|-----------|
| 1. ARTE® WOOD STOVE - A GREEK QUALITY PRODUCT | 28 |
| 2. FACTS ABOUT WOOD AND THE ENVIRONMENT | 28 |
| 2.1 Why Use Wood? | 28 |
| 2.2 Buying Firewood | 28 |
| 2.3 Storing Your Wood | 29 |
| 2.4 Wood types and calorific value | 30 |
| 3. APPROVALS AND CERTIFICATIONS | 31 |
| 3.1 Approval | 31 |
| 3.2 CE conformity | 31 |
| 3.3 Ratings plate | 31 |
| 4. PACKAGING | 32 |
| 5. FIRE PROTECTION | 32 |
| 5.1 Safety distances | 32 |
| 5.2 General safety instructions | 32 |
| 5.3 Chimney safety instructions | 33 |
| 5.3.1 Common chimney problems | 33 |
| 5.4 Conduct during malfunctions - SHUTTING DOWN safely | 33 |
| 6. OPERATING INSTRUCTIONS | 34 |
| 6.1 Before firing the stove for the first time | 34 |
| 6.2 About the stove | 34 |
| 6.3 General information | 34 |
| 6.3.1 When the stove paint dries | 34 |
| 6.3.2 Preparations for firing | 34 |
| 6.3.3 Heating in the transition time and in difficult conditions | 35 |
| 6.4 Ventilation kit for air heating | 35 |
| 6.4.1 Electronic board and use of it | 36 |
| 7. FIRING THE STOVE | 37 |
| 7.1 Traditional firing | 37 |
| 7.2 Firing the stove without CO emissions (TOP-DOWN) | 37 |
| 8. SECONDARY COMBUSTION | 39 |
| 9. CLEANING AND CARING FOR YOUR STOVE | 40 |
| 9.1 Exterior Maintenance | 40 |
| 9.2 Internal maintenance | 40 |
| 9.3 Cleaning the Stove and the Flue | 42 |
| 9.4 Inside parts | 43 |
| 9.5 Leaving the stove for extended periods | 44 |
| 10. TIPS & TRICKS | 44 |
| 11. DIMENSIONS | 45 |
| 12. TECHNICAL DATA | 46 |
| 13. WARRANTY | 47 |
| 13.1 Warranty terms | 47 |
| 13.2 Excluded from the warranty | 47 |
| 13.3 Responsibility | 47 |
| 13.4 Extraordinary maintenance | 47 |
| 13.5 Responsibility for installation | 47 |
| 13.6 Use | 48 |
| 13.7 Legal guarantee | 48 |

1. ARTE® WOOD STOVE - A GREEK QUALITY PRODUCT

Thank you for buying an ARTE® wood stove – we believe that you will have as much pleasure from our product as we have.

Your ARTE® wood stove is made in such a way, to extract the maximum possible energy from the wood with the minimum possible emissions, using the most innovative technology and the most robust design - made in Greece!

These instructions contain interesting and informative facts and all you need to know about the subjects of heating, wood, and operating your ARTE® wood stove. Please read these instructions carefully before using your stove for the first time and keep them in a safe place.

The manuals which are enclosed with the product must be kept throughout the product's entire service life.

2. FACTS ABOUT WOOD AND THE ENVIRONMENT

2.1 Why Use Wood?

With proper forest management, burning wood does not deplete the earth's resources. Heating with wood usually does not contribute to global warming. The young trees that replace the trees in your wood stove absorb carbon dioxide from the air. Burning firewood releases only as much CO₂ as the tree has absorbed from the atmosphere during its growth. Wood rotting in the forest generates the same amount of CO₂ as the same wood burning.

Besides being environmentally friendly, the heat from a wood stove warms you like the warming rays of the sun during the sunny winter days. It is the radiated heat that transmitted by electromagnetic waves in the infrared range. Even when the air is very cold you can feel the warm rays of the sun on your skin.

Another advantage to wood is that it is produced locally, which creates local employment, and more tax revenues stay in the province.

2.2 Buying Firewood

Where can I get my firewood?

Buying ready-to-burn firewood

Regenerated ready-to-burn firewood can be purchased from dealers:

- > Stove-ready, stored for at least two years
- > Pre-dried, stored for one year
- > Fresh from the forest

The ideal residual moisture is 12 - 15% and should be no higher!

Whether you have cut your own wood or bought it, the important thing is: **the wood should be dried for at least two years before it is burned**

2.3 Storing Your Wood

The full potential for heat will not be realized if you neglect the simple chore of piling and protecting your wood. Proper storage is essential to avoid moisture, bacteria, and insect problems in your home.

To avoid problems with insects and moisture, store the wood as far from your house as is practical. Do not store wood in your basement; one cord of wood can give off more than 500 liters of water. The basic rule is to hide the wood from water, but not from the sun or wind (Figs. 1 & 2). Green wood will dry slowly or not at all if unprotected, while seasoned wood left unprotected may become unseasoned.

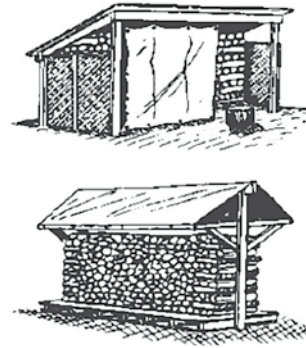

Fig. 1

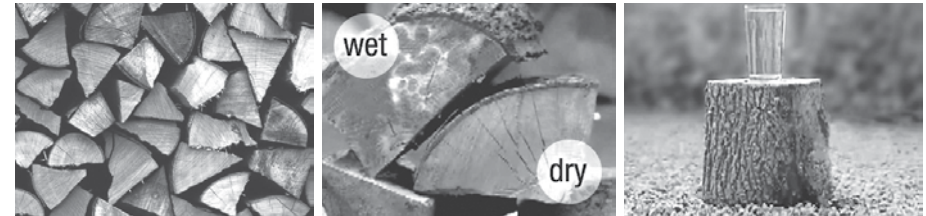

Fig. 2

There are three basic rules to follow when storing wood:

1. Allow air circulation by piling one tier wide if possible
2. Protect wood from rain and snow by covering with a tarp or woodshed roof
3. Pile wood off the ground on scrap lumber or wooden pallets

The time-honored way to cure wood is to buck, split, and stack wood off the ground for one full year. However, wood can generally be reduced to 20 per cent moisture content in two to three months. The ideal 10% to 15% may take longer (almost 18 months).



2.4 Wood types and calorific value

A wood's efficiency does not depend only on its type, but also on its humidity, as well as the temperature of the combustion chamber.

For more efficient and longer burning, without emission of hazardous substances, woods must be dry. Ideally, their humidity percentage must not exceed 10% to 15%.

If this percentage is over 20%, the wood is not burned properly, whereas if the piece of wood has been cut recently, the humidity is over 60% making it unsuitable for burning. The reason for that is that the fire will be weak and pale and will produce dense smoke, unburned tar and creosote, soiling the ceramic glass and the smoke duct.

It is preferable to get your wood supplies during the summer months and store them, to ensure better combustion quality during the winter.

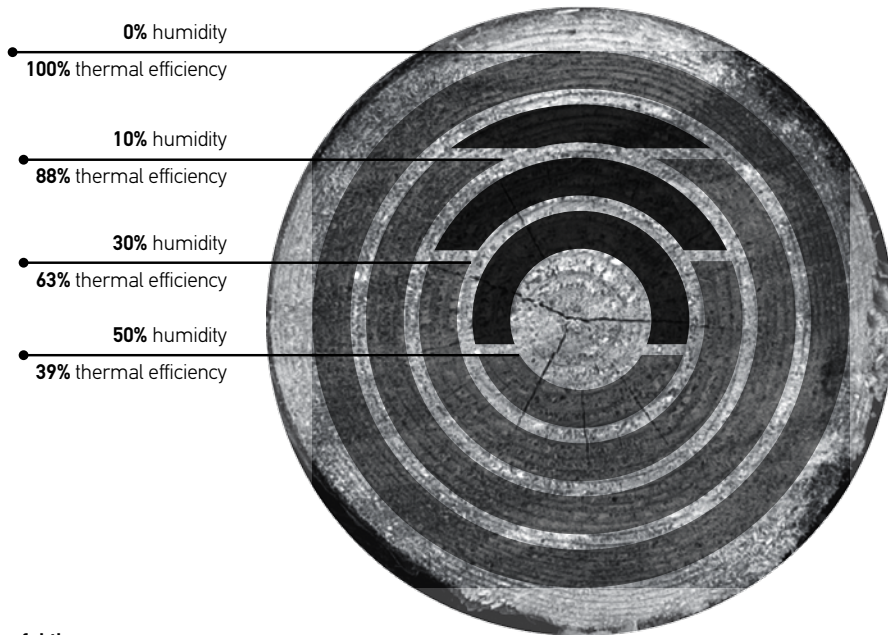

Useful tips

1. Always choose dry firewood
2. Avoid wood that pops (chestnut, conifers such as cedar, spruce and pine), as they may damage your fireplace or the smoke duct
3. Pay attention to the size of the woods. Good firewood must have been cut at least twice
4. You should prefer oak, beech, olive wood, hard wood with high density since they will burn for longer

Briquettes

They ignite very easy, and burn slowly. They are economically advantageous because you will burn smaller quantities compared to common firewood and they are easily stored. Also, you have less quantity of ashes vs. to wood.

Birch

Soft wood ignites easily with great thermal energy production. It produces less smoke and ash compared to other wood and burns silently. The same characteristics apply for lime and chestnut.

Beech

Hard wood ideal for firewood requires a high temperature to ignite. It weights a lot, it is dense and burns with a calm and long fire for a longer time. Best when well seasoned. The same applies for oak, but seasoned for 2-3 years.

The various wood types have various calorific values

| Wood Type | Thermal Capacity (Kcal/h-1Kg) |
|--------------------------|-------------------------------|
| Briquette | 5.000 |
| Birch | 4.800 |
| Walnut | 4.731 |
| Oak | 4.619 |
| Beech | 4.578 |
| Fir | 4.588 |
| Common Oak | 4.548 |
| Pine | 4.457 |
| Olive wood | 4.100 |
| Poplar | 4.022 |
| <i>860Kcal/h = 1Kw/h</i> | |

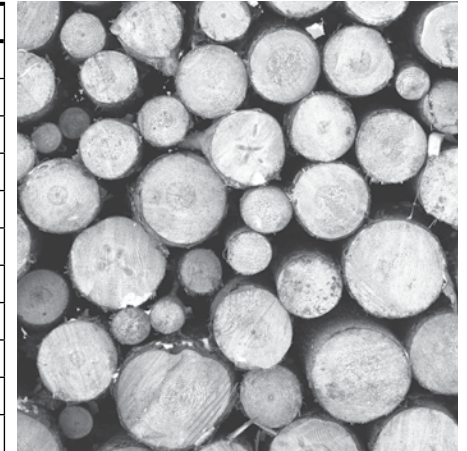

The values are based on 15% residual wood moisture

An ARTE® Wood Stove can be fired with all of the above wood types

3. APPROVALS AND CERTIFICATIONS

3.1 Approval

Your ARTE® wood stove has been tested under the following standards: EN13240

3.2 CE conformity

The manufacturer, G. Karnoutsos & CO, confirms that the ARTE® wood stove conforms to the standards under EN 13240 and that the quality requirements are constantly monitored.

3.3 Ratings plate

The ratings sing is located on the bottom left hand side at the back of the stove.

4. PACKAGING

ARTE® is dedicated to protecting the environment, using wherever possible recyclable and least possible packaging materials without cutting corners on product transportation safety.

Unpacking

1. Remove the stretch film and the nylon waterproofing. (be careful with sharp instruments)
2. Remove the polystyrene from the upper section of the clipper, taking off all the other pieces inside the combustion chamber and ash drawer.
3. Unscrew the screws (1) from the wood-burning stove so as to free it from the palette.
4. Carefully lift the stove off the palette and place it where it is to be installed.

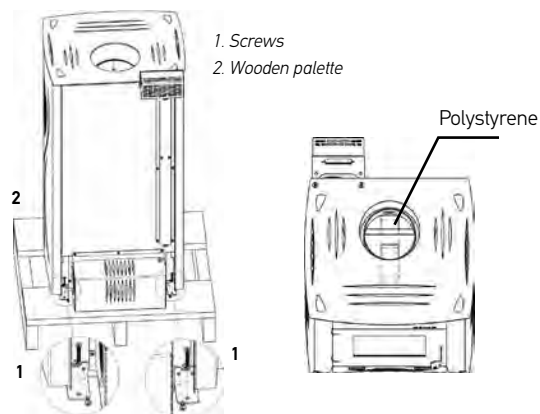

5. FIRE PROTECTION

Installation of a wood stove must be according to local codes and regulations in each country.

All local regulations, including those which refer to national and European standards, must be observed when installing the product. The installation can only be put into use after it has been checked by a qualified inspector. Contact your local building authorities before installing a new wood stove.

5.1 Safety distances

Safety distance A

The side and rear panels must be no closer than 25 cm to flammable materials e.g. furniture, cloths, etc.

Safety distance B

Smoke pipes must be no closer than 25 cm to flammable materials

Safety distance C + D

Flammable floor materials must be no closer than 50 cm to the front and 30 cm to the sides

Safety distance E

Firing chamber apertures must be no closer than 80 cm to flammable materials within the radiation zone

Safety distance F

The minimum distance from the ceiling is 60 cm

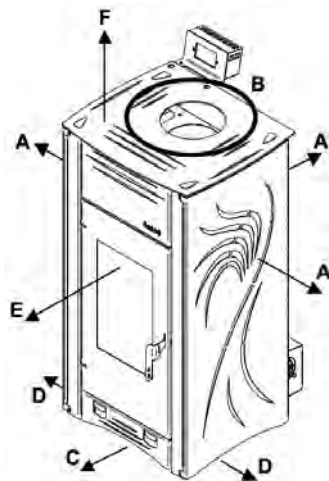

5.2 General safety instructions

- > Never leave children alone or unattended at a burning stove
- > Teach your children how to behave properly and operate safely the stove

- > Avoid touching the outside surfaces when the stove is operating. Every stove gets hot when fired: risk of burning!
- > It is prohibited to use the stove as a waste incinerator
- > Do not burn, refused or painted wood
- > Dispose of the ashes only after they have cooled completely
- > Ash should be placed outdoors or be emptied in a place where it will not present a potential of hazard
- > Inform your specialized dealer without delay of defect gaskets
- > Do not use chemicals or fluids to start the fire

Observe the information in our operating instructions and make a proactive contribution to fire prevention and the protection of our environment.

5.3 Chimney safety instructions

The condition and functionality of your chimneys must be inspected by a chimney sweep or specialist before the ARTE® wood stove is installed. (EN 13384-1 & EN 13384-2)

This will provide the optimal conditions for trouble-free heating.

5.3.1 Common chimney problems

- > Retrofitting an old chimney: Frequently, old chimneys are too big for today's wood stoves. That means the amount of air they draw is not proportional to the amount of heat the stove produces. A too-big chimney means you'll burn more wood than you need, and likely spend more time than necessary on fire maintenance. You'll need to install a "liner" stovepipe within the chimney. It should run the entire length of the chimney, and nowhere along its length should it be any bigger than the stove's exhaust opening. But -- before you go jamming pipe up the chimney -- you should know how the chimney was built, and what sort of insulation it contains. The heat produced by a wood-burning stove is different from the heat produced by an open fireplace, and your chimney may not be up to the task without some work.
- > Setting the stovepipe to minimum height requirements: A short chimney may look nicer (though that's a matter of opinion), but it may not supply an optimal draft to the stove. Work with a professional to figure out the right stovepipe height for your stove.
- > Running too much horizontal stovepipe: A venting system works best when it's vertical. Some homeowners, rather than create chimney holes in the roof, run stovepipe out windows or through walls. But this is a very bad idea.
- > Running the stovepipe along an exterior wall: This isn't a safety issue so much as an efficiency issue. The stove will heat more of the house if the pipe travels up along an interior wall, so all the heat from the pipe stays in the house.
- > Creating too many twists and turns: Venting systems should be direct and straight. Twists and turns in a stovepipe invite the buildup of creosote, and that raises the risk of fire.

5.4 Conduct during malfunctions - SHUTTING DOWN safely

In rare cases, also a pilot fire can fail to generate a draught in the flue.

You must then ask your chimney sweep for advice. On no account must you attempt to light a larger fire. When smoke escapes from your stove, air the room immediately and contact your chimney sweep. You should then refrain from firing your stove.

6. OPERATING INSTRUCTIONS

6.1 Before firing the stove for the first time

You have now been instructed by one of our specialized dealers on how to fire your ARTE® wood stove.

In these operating instructions we wish to set down each step that you must take if you are to encounter no problems when operating your ARTE® wood stove.

Your specialized dealer will be pleased to assist you with any questions you may have.

ARTE® wood stove is equipped with the following controls:

6.2 About the stove

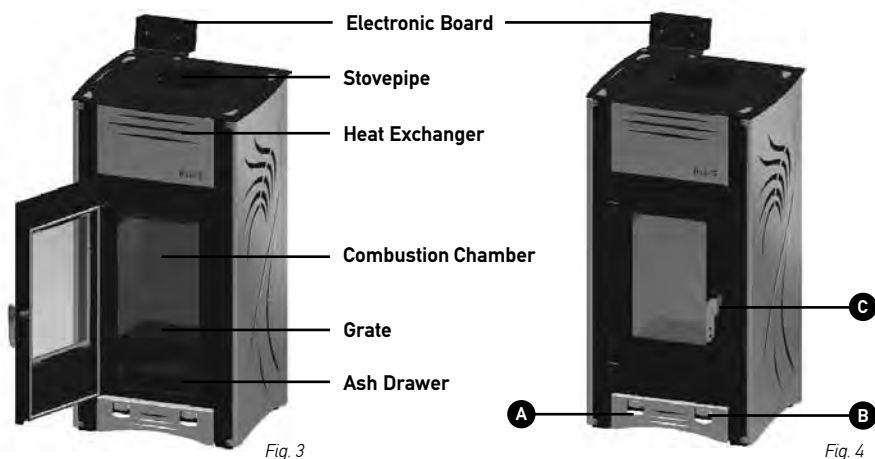

| Postcombustion Control, Fig. 4A | Ignition Control, Fig. 4B | Handle for door, Fig. 4C |
|---------------------------------------|---------------------------------------|---------------------------------------|
| Pushed in: Closed Pulled out: Open | Pushed in: Closed Pulled out: Open | Door is opened by pulling handle out. |

6.3 General information

6.3.1 When the stove paint dries

When the stove is fired for the first few times the paint on the stove emits an odour when it dries.

Let the fire burn with a high draught until all traces of the gas have disappeared and no smoke or odour can be detected.

The gas is not toxic but the room should be thoroughly ventilated.

6.3.2 Preparations for firing

Have ready an adequate supply, of chopped firewood, ecofriendly lighting aids and kindling. You are best storing the wood in a warm room for a number of days before firing.

6.3.3 Heating in the transition time and in difficult conditions

In damp or foggy weather, at outdoor temperatures from ≥ 15 °C, and during the transition time you are advised to light a pilot fire before firing the stove proper. This serves to displace the cold, heavy air in the chimney and to create the right conditions for the optimal extraction of smoke.

This pilot fire is lit with paper in the chimney's inspection aperture until extraction is assured.

6.4 Ventilation kit for air heating (optional)

A blower can be installed at the back of your stove. This option is necessary if you wish to redistribute into the house or room the heat of your stove. By forcing hot air, the blower enables you to extend the radiation and convection power of your stove.

Although it is ready to install, this appliances must be electrically connected and grounded in accordance with local codes.

DO NOT cut or removes the grounding prong from the plug.

DO NOT route the power cord beneath the heater.

The air heating ventilation kit has an electronic board with ten speeds that start when the air temperature reaches 45°C. When temperature drops, it stops automatically. The installation is very simple (**Ready to install**):

- > Knock out with a hammer, the cut out cover (**Fig. 5A**)
- > Attach the blower to the stove with the five screws (**Fig. 5B**)
- > Attach the wire column to the stove with the six screws (**Fig. 5C**)
- > Attach the electronic board to the stove with the two screws (**Fig. 5D**)
- > Plug the socket and is ready to heat your room with the **280m³/h blower**

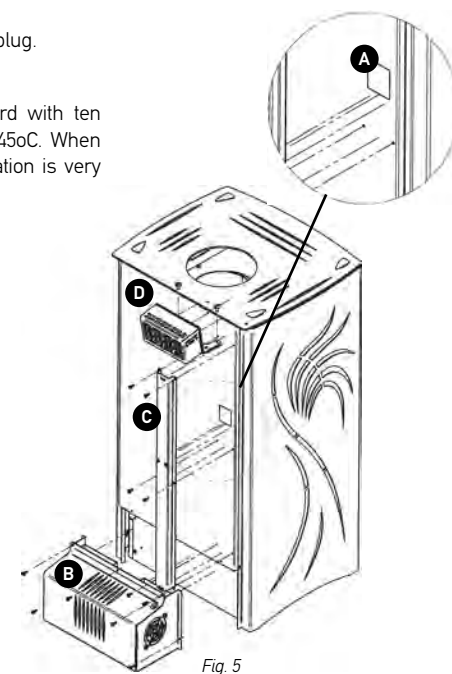

6.4.1 Electronic board and use of it

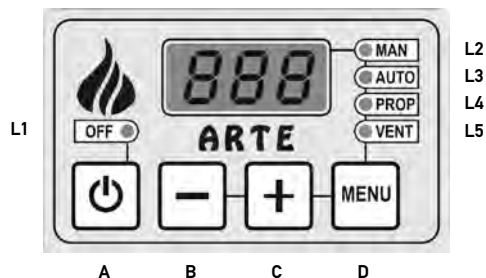

> ON / OFF:

The On/Off of the controller is pushing the button **A**
The state OFF is signaled through the led L1

> FUNCTIONING Modality

MANUAL: advice signal **MAN**

The fan is at the set speed independently by the Probe's temperature.

AUTOMATIC: advice signal **AUT**

The Fan starts at the set up speed when the probe's temperature is higher than the settled Thermostat (45°C).

PROPORTIONAL: advice signal **PROP**

The fan increases automatically its speed according to the probe's temperature (from 45°C plus).

If you forget to open the thermostat (OFF) when you had lighted the stove and the probe's temperature is becoming higher than 100°C the device goes in ON automatically in MANUAL Modality, and after 10 seconds the device goes automatically in the Proportional Modality until the temperature will become (90°C) and it is going again in MANUAL Modality. It's going to repeat this function again and again until you select another function.

ALARM Function: if probe's temperature is higher than (130°C) an acoustic signal is activated. This signaling can be deactivated for 5 minutes by pushing a button. After 5 minutes, if there's again the condition of alarm, it is activated again.

> Main MENU:

FUNCTIONING Modality Selection

Press **D** key to see the current modality: it's signaled by the display and the led. Pressing again the **D** key, you can select cyclically one of three functioning modality signaled on the display and by the led.

The setting is automatically memorized after 4 seconds

The **L5** shows the status of the Fan

Functioning Speed Selection

Pressing **B** or **C** keys the setting of the current fan speed is visualized or modified **P0** = OFF (only manual); **P1** = Min. Speed; **P10** = Max. Speed

This function is not available in the PROPORTIONAL Modality

In the AUTOMATIC Modality the speeds that can be set are **P1 ÷ P10**

> FAILURE OR ALARM SIGNALS

The controller can signal the failure of the probe. Blinking message for the failure signal:

Lo: indicates a low temperature (temperature under 0°C): **Probe Open or Disconnected**

Hi: indicates a high temperature (temperature over 180°C): **Probe in Short Circuit**

7. FIRING THE STOVE

7.1 Traditional firing

When first lighting the stove, a large volume of air is needed. When the stove is cold, you should leave the door open to the first latch so there is an air gap around it (or if you do not have a handle with two latch, 1 - 2cm) for the first few minutes and open the primary & secondary air supply completely.

While the door is open, do not leave the stove unattended

To form a reasonable bed of ash on the floor of the stove, you should use 1 - 2 kg of dry kindling at the initial lighting. If possible, maintain a 2 - 3 cm layer of ash on the floor of the combustion chamber for added insulation.

1. Put 2 - 4 fuel tablets or 7 - 10 rolled up sheets of newspaper underneath 1 - 2 kg of dry kindling
2. Open the primary & secondary air by pulling it out all the way (**Fig.4 A&B**)
3. After the fuel tablets/rolled up sheets have caught fire, leave the fire door ajar about 1 - 2 cm (or to the first latch of handle), so that the chimney draws well
4. When you can see that the chimney is hot enough to draw (after 5 - 10 minutes), close the door. If all the necessary conditions are met, a thick layer of embers will have been formed in the combustion chamber after another 15 - 20 minutes, and there will be a high temperature in the combustion chamber, which is necessary in order to be able to continue the combustion.
5. If the condition in step 4 is met, place 2 - 3 pieces of wood with a total weight of 1.5 - 3 kg over the embers, with a distance of approximately 1 cm
6. Open the air supply to maximum, and close the door. The fresh wood will be lit within 2 - 3 minutes. If it does not light, open the door slightly to allow in enough air to ignite the wood. Close the door again once the wood has caught. Also close the primary air.
7. Reduce the amount of secondary air to the desired position, and the optimal combustion will continue. Make sure that there is always enough air (oxygen) to maintain clear, lasting flames when, and after, reducing the amount of combustion air.
8. Once the fire has been reduced to a thick layer of embers, a new portion of wood can be added by repeating steps 5 & 7

7.2 Firing the stove without CO emissions (TOP-DOWN)

1. Open the primary & secondary air by pulling it out all the way (**Fig.4 A&B**). If necessary, keep the door slightly open about 1 - 2 cm (or to the first latch of handle).
2. Place 2-3 pieces of wood with a total weight of 1.5 - 3 kg and a length of 30 - 35 cm in/out on each side of the base (**Fig. 6 A&B**)

In order to avoid sooting on the glass, it is important that the log is not placed adjacent to the glass on the product

3. Put 2 - 3 fuel tablets or 5 - 8 rolled up sheets of newspaper between these woods
4. Add some kindling wood (1 - 2 kg) in a criss-cross pattern on top (Fig. 6 A&B)
5. Finally, place a medium-sized log on the top of the pile and light the tablets/newspaper

The maximum height of the pile of the wood should be just below the secondary air holes.

6. When you can see that the chimney is hot enough to draw (after 5 - 10 minutes), close the door and the primary air (Fig. 4B)
7. Reduce the amount of secondary air to the desired position, and the optimal combustion will continue. Make sure that there is always enough air (oxygen) to maintain clear, lasting flames when, and after, reducing the amount of combustion air (Fig. 4A).
8. Once the fire has been reduced to a thick layer of embers, a new portion of wood can be added. Stoke the stove frequently but only add small amounts of fuel max 3 kg at a time. If the stove is filled too full, the heat created may cause extreme stress in the chimney. Add fuel to the fire in moderation.



Fig. 6A (Horizontal)



Fig. 6B (Vertical)

The fire is best when it is burning well and the smoke from the chimney is almost invisible.

Avoid smouldering fires as this produces the most pollution.

WARNING: *Wood stoves must never be left unattended with the door open.*

If the door is left partly open, gas and flame may be drawn out of the fireplace stove opening, creating risks from both fire and smoke. We recommend that you fit a smoke detector in the room where the stove is installed.

DO NOT OVERFIRE THIS HEATER. *Over firing may cause a house fire, or can result in permanent damage to the stove. If any part of the stove glows, you are over firing.*

The maximum recommended weight of wood fuel per load is 3.0 kg/h (approx 3 split logs).

Rules of wood burning

If you want less heat, put fewer logs on the stove and reduce the amount of air. It is still important to maintain a good layer of embers.

Less heat - less wood - less air

Greater heat - more wood - more air

Soot deposits will settle on the glass if the stove is run too slowly or if your wood is not well seasoned.

We would strongly recommend that you do not leave your stove alit at night. It harms the environment, and constitutes very poor use of the wood, as the gases in the wood do not ignite at the low temperature, but settle as soot (unburned gases) in the chimney and stove instead.

8. SECONDARY COMBUSTION

One of our objectives is to develop wood burners that burn cleaner and more economically than any other product in relation to the environment.

In traditional heating appliances, wood combustion is never complete. This has as results:

- > low efficiency (Partial use of the calorific value of wood resulting in significant wastage)
- > pollution (formation of carbon monoxide: CO)

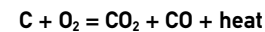

Thanks to the Double combustion technology applied to our fireplaces and wood stoves, the following reaction take place inside the burner:

Primary combustion:

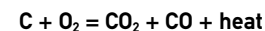

Double combustion:

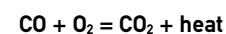

During the primary combustion of wood, heat and fumes of carbon dioxide, carbon monoxide and water vapors are produced.

During the secondary combustion, we add pre-heated oxygen at the upper part of the fire, as a result a re-ignition of the carbon monoxide starts, giving us a high thermal output, along with minimization of the operating costs and decrease in polluting emissions.

This way, we achieve the production of carbon dioxide and not monoxide which cannot be absorbed by plants.

9. CLEANING AND CARING FOR YOUR STOVE

When performing maintenance on your stove, always protect yourself, using safety goggles and gloves

9.1 Exterior Maintenance

The stove surface is painted with heat-resistant paint. It is best kept clean by vacuuming with a soft brush attachment or by wiping with a lint-free cloth.

Over a period of time, the painted surface may become slightly grey. A canister of touch-up ARTE® spray paint should be available from your stove supplier. This can be applied - in accordance with the instructions - in just a few minutes. When first firing, after touching up, the stove will give off a slight smell as the paint cures. Make sure to ventilate the room well during this phase.

9.2 Internal maintenance

Ash disposal

Empty the ash pan on a daily basis or as needed. Ash allowed to build up towards the underside of the grate will trap heat and could cause premature failure of the grate.

Empty the ash pan according to this procedure:

- > Open the front door, and use a shovel or poker to stir excess ash through the ash slots in the grate down into the ash pan
- > Take out the ash pan, making sure to keep it level to avoid spilling ash
- > Dispose the ash in a metal container with a tight fitting lid
- > The closed container of ashes should be placed on a noncombustible floor or on the ground, well away from all combustible materials, pending final disposal. If the ashes are disposed of by burial in soil or otherwise locally dispersed, they should be retained in the closed container until all cinders have thoroughly cooled.
- > Return the ash pan to its original position in the stove, and close the door

Never empty a stove in operation.

Never use your household or shop vacuum cleaner to remove ash from the stove.

Always remove and dispose of the ash properly.

Glass

If the stove is generally run at the correct temperatures, there should be little or no dirt on the glass. If dirt does settle during lighting, most will burn off as temperatures increase.

For normal cleaning, moisten a paper towel with warm water and add some ash from the burn chamber. Rub it over the glass and then clean the glass with clean water. Dry it well.

For heavier deposits that will not clean, use glass-cleaner, applied when the glass is cold, in accordance with the instructions. Never use abrasive cleaners on the glass surface.

Reasons for dirty glass

- > Fuel too wet
- > Logs too large or not split
- > Combustion temperatures too low

To reduce the risk of breaking the glass, avoid striking the glass or slamming the door.

Replace broken glass immediately.

Do not operate your stove if the glass in the door is damaged.

If you need to replace the glass, it should be replaced with the high temperature ceramic glass supplied by ARTE®, contact your ARTE® dealer.

Gasket

The gasket around the perimeter of the door may harden over a period of time. It should be replaced if it becomes difficult to close the doors or if air starts to leak in around the perimeter of the doors, causing the fire to become a little less controllable. An ARTE® rope gasket kit is available from your stove supplier.

Internal service parts

The flame-path equipment - consisting of the ash pan, grate, firebricks, Cast iron fire plates, glass, flue collar and baffle - are subject to the extremes of heat produced by the fire. From time to time, one or other of these parts may need replacing as a matter of routine maintenance.

The flame-path equipment, the ceramic rope and the paint finish are not covered by guarantee.

All of these service parts can be bought from your ARTE® dealer, and we recommend that damaged parts are replaced as soon as possible to avoid collateral damage.

Should the baffle be distorted by an over fire, the stove will still function, although its efficiency may be compromised. Replace it as soon as possible.

Reasons for fast internal wear and tear

- > Persistent heavy firing
- > Soot and ashes left to accumulate

9.3 Cleaning the Stove and the Flue

When wood is burned slowly, it produces tar and other organic vapors, which combine with expelled moisture to form creosote. The creosote vapors condense in the relatively cool chimney flue of a slow-burning fire. As a result, creosote residue accumulates on the flue lining. When ignited this creosote makes an extremely hot fire.

Check for soot above the baffle plate and around the flue outlet every month or so to start with. If the stove suddenly becomes sluggish, check for a soot fall around the flue collar or in the flue/chimney.

The chimney and chimney connector should be inspected at least once every two months during the heating season to determine if a creosote buildup has occurred. If creosote has accumulated, it should be removed to reduce the risk of a chimney fire.

Clean the flue/chimney - all the way from the stove to the flue terminal point above the house.

A good routine is to clean the flue after each heating season in any case, and inspect prior to the season to ensure that bird's nests or other blockages have not occurred during the off season.

Chimney sweeping

Inspect the system regularly during the heating season as part of a regular maintenance schedule.

To inspect the chimney, let the stove cool completely. Then, using a mirror, sight up through the flue collar into the chimney flue. If you cannot inspect the flue system in this fashion, the stove must be disconnected to provide better viewing access.

Clean the chimney using a brush the same size and shape as the flue liner. Run the brush up and down the liner, causing any deposits to fall to the bottom of the chimney where they can be removed through the clean-out door.

Clean the chimney connector disconnecting the sections, taking them outside, and removing any deposits with a stiff wire brush. Reinstall the connector sections after cleaning, being sure to secure the joints between individual sections with sheet metal screws.

If you cannot inspect or clean the chimney yourself, contact your local ARTE® Dealer or a professional chimney sweep.

If you do experience a chimney fire, act promptly and:

- > Close the air control.
- > Get everyone out of the house.
- > Call the Fire Department.

Annual maintenance

Before the heating season, perform a thorough cleaning, inspection and repair:

- > Thoroughly clean the chimney and chimney connector.
- > Inspect the chimney for damage and deterioration. Replace weak sections of prefabricated chimney. Have a mason make repairs to a masonry chimney.
- > Inspect the chimney connector and replace any damaged sections.
- > Check gasketing for wear or compression, and replace if necessary.
- > Check the glass for cracking; replace if needed.
- > Check door and handle for tightness. Adjust if needed.

How to clean the inside parts of ARTE®

When cleaning the inside parts of the stove in connection with the annual visits from your local chimney sweep we recommend that you remove the inside parts from the fire chamber. Please be careful as the vermiculite parts are porous thus fragile. (Chapter 9.4)

Cleaning of the stove must be done when the stove is cold.

9.4 Inside parts

Refractory plates: Follow the installation sequence

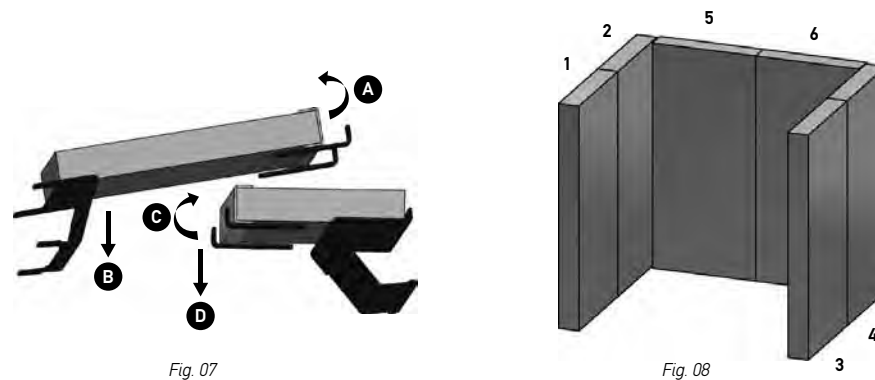

9.5 Leaving the stove for extended periods

IMPORTANT: If the stove is to be left unused for any period of time, clean it out thoroughly and leave the air control slightly open to allow airflow. Make sure that the flue does not allow rainwater to come anywhere near the stove, install a chimney cap, but do not block off the flue completely.

These measures should ensure there is a slight movement of air through the stove, and that the body of the stove remains dry, right into the corners.

Any ash left within an unfired stove can attract moisture like blotting paper. If moisture is allowed to settle within the stove, rust will form. Rust expands as it takes a grip. This can lead to undue pressure on the stove joints, and this in turn may result in damage to the stove.

NOTE: It is best to thoroughly clean the stove after the heating season has concluded. Adding a dessicant, such as kitter litter, into the ash pan helps absorb moisture during the summer months. Be sure to remove this prior to the heating season.

We hope you have many years of carefree warmth with ARTE® wood stove. Some initial experimentation with loading and running techniques will decide your normal routine. If you have any problems after this short learning phase, please refer to your stove dealer. Should they be unable to help for any reason, please contact us in writing at the address on the front of this publication.

10. TIPS & TRICKS

Wood does not ignite when stove is fired; fire just smoulders away; fire extinguishes:

- > Open combustion air slide
- > Kindling unsuitable
- > Wood too damp
- > Firewood too thick
- > Ash drawer full

Heavy shooting in the firing chamber; heavy sooting on the window:

- > Open combustion air slide
- > Too little wood
- > Firewood damp or too thick

Smoke escapes from the stove:

- > assure adequate extraction in the chimney, light pilot fire
- > provide for adequate supply of air

Your specialized dealer will be pleased to assist you with any further questions you may have.

11. DIMENSIONS

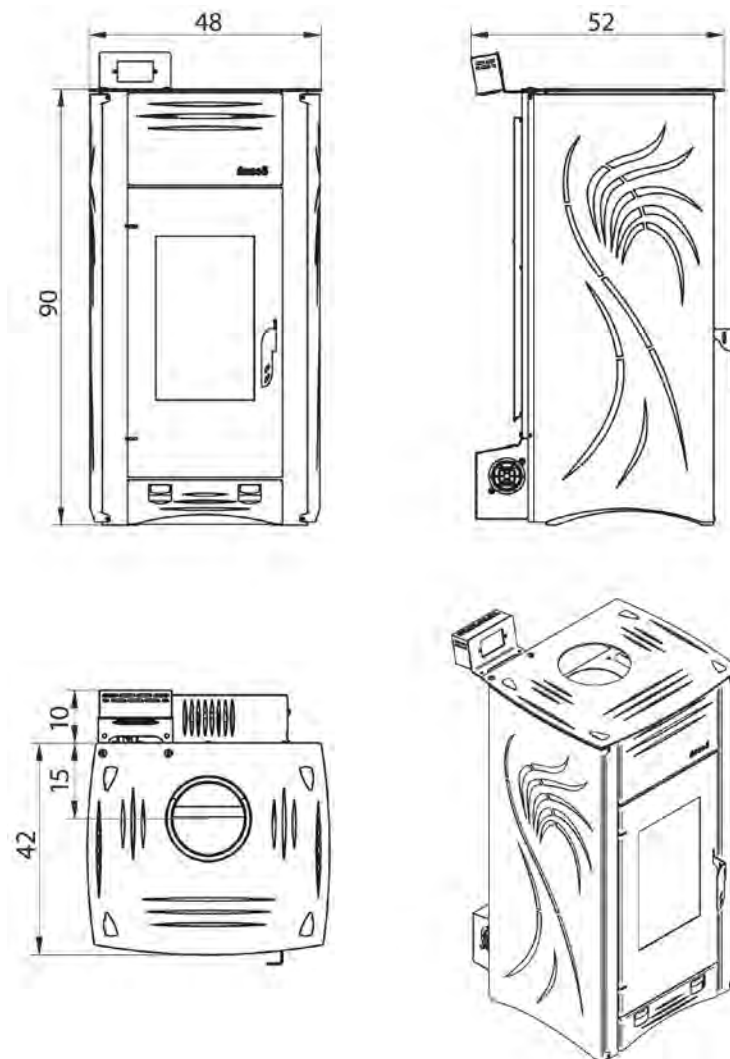

12. TECHNICAL DATA

| TECHNICAL DATA | UNITS | APOLLO | APOLLO AIR |
|--|----------------|-----------------|---------------|
| *Global heat rating (efficiency) | Kcal/h Kw | 9890 11,5 | 10320 12,0 |
| Hourly fuel consumption | Kg/h | 3,1 | |
| Global efficiency | % | 78,1 | 81,3 |
| Smoke temperature | °C | 227 | 220 |
| Emissions of CO (at 13% of O ₂) | % | 0,25 | 0,24 |
| Performance range (min-max) | Kw | 5,5 - 17,5 | |
| Fuel | - | Wood, Briquette | |
| Burner dimensions (W x D x H) | cm | 33 x 29 x 41 | |
| Flue draught | Pa | 12[±2] | |
| Recommended hourly consumption on fire wood | Kg/h | 1,6 - 4,7 | |
| Heatable surface | m ² | 80 | 85 |
| Weight | kg | 79 | 87 |
| External air intake. Its section must be increased 20% for each additional meter after the 1 metre | cm | - | |
| Smoke outlet diameter | cm | Ø 15 | |
| Stove suitable for rooms of no less than | m ² | 30 | |
| *The stove works with intermittent combustion. Intermittent combustion in this context means normal use of the wood stove, i.e. fuel is added as soon as the fuel has burnt down to a suitable amount of embers. | | | |

| Flue | Diameter (cm) | Height (cm) |
|---|---------------|-------------|
| The inside section of the flue must be increased 10% for each 500m in altitude above sea level. | Ø 15 | ≥ 400 |
| | Ø 20 | ≥ 350 |

13. WARRANTY

We grant a two year warranty for your new ARTE® wood stove. The warranty period begins on the day the stove is installed and tested by the specialized dealer. We also grant a one year warranty for all the electrical parts (if any are installed).

Warranty claims become valid when the purchase price for the stove has been paid in accordance with the agreement and the warranty certificate has been completed and returned within thirty days to ARTE® G. Karnoutsos & CO.

If one of these conditions is not fulfilled the minimum warranty of six months applies.

13.1 Warranty terms

- > Proper installation by a specialized dealer
- > The wood stoves are handled in accordance with these operating instructions
- > No continuous firing
- > No overheating
- > Regular maintenance / cleaning (once a year)
- > There must be no modifications to the stove structure: these can cause malfunctions and permanent damage

13.2 Excluded from the warranty

- > Wearing parts like gaskets, cast grate, fireclay, and glass
- > Smoke and soot damage
- > Natural discoloration or deviating colors on the outer cladding
- > Cracks in the combustion chamber that have no effect on the safe functioning of the ARTE® wood stove
- > Damage incurred through failure to observe these operating instructions
- > Damage covered by an insurance policy or other agreement

13.3 Responsibility

Upon delivery of this manual ARTE® declines all liabilities, both civil and penal, for any accidents that may derive from the total or partial failure to comply with the specifications contained in it.

ARTE® also declines all responsibility resulting from an improper use of the appliance, incorrect use by the user, from unauthorized alterations and/or repairs, or the use of non-original or non-specific spare parts for this particular stove.

13.4 Extraordinary maintenance

Extraordinary maintenance on the stove model to which this manual refers, must be carried out by qualified personnel.

13.5 Responsibility for installation

It is not the responsibility of ARTE® to carry out the work needed to install the stove. Such works are entirely up to the installer who is requested to check the flue and air intake and to check if the installation solutions proposed are feasible. All applicable standards and local, national and European legislation in force in the country where the stove is installed must be respected.

13.6 Use

Use of the appliance is subject to compliance with all the safety standards established by the relevant laws in force in the place of installation, in addition to the instructions contained in this manual.

13.7 Legal guarantee

The user may only make use of the legal guarantee, as under the EEC directive 1999/44/CE, if he has scrupulously complied with the regulations indicated in this manual, and more specifically:

- > To work always within the stove's limits of use
- > Maintenance must be constant and careful
- > Only allow people who are capable and who have been suitably trained to use the stove

Failure to comply with the instructions provided in this manual will invalidate the guarantee immediately.

NOTES



Factory - Head Offices

Makrigianni Str.
Evosmos | Thessaloniki | Greece

Mail

P.O. Box 40 124, P.C. 564 10
Stavroupoli | Thessaloniki | Greece

t. +30 2310 684 148

f. +30 2310 684 149

e. info@arte-fireplace.com

www.arte-fireplace.com